



2K Piston Inserter Conversion Instructions

Tools Required:

- 2.5 mm, 3 mm and 4 mm Hex Wrenches
- Small Adjustable Wrench
- Flat Screwdriver
- Strap Wrench

Original Document

Electronic pdf files of Nordson
EFD manuals are also available
at www.nordsonefd.com



Convert from 200mL to 50mL (7015506)

WARNING! Disconnect the inlet hose from the pressure regulator.

Remove the necessary 200ml parts:

- a. Loosen and remove the screw holding the funnel block to the yoke using a 3mm hex wrench and remove the funnel block.
- b. Loosen the four screws holding the sheet metal guard using a 2.5mm hex wrench and remove the guard. The screws should be left in place and may be re-tightened.
- c. Remove the lower nest and standoffs using a 4mm hex wrench and an adjustable wrench. (The standoffs and screws can be left in place if desired.)
- d. Remove the hose from the fitting on top of the pneumatic cylinder.
- e. Loosen the jam nut at the top of the rocker assembly by turning counter-clockwise with an adjustable wrench.
- f. Loosen the cylinder from the frame by turning counter-clockwise using the strap wrench.
- g. Holding the rocker assembly, turn the pneumatic cylinder counter-clockwise until it separates from the frame and the rocker assembly separates from the piston rod. Set the cylinder and rocker assembly aside.



Convert from 200mL to 50mL (7015506)

Install the necessary 50ml parts:

- a. Position the rocker assembly with the rear anti-rotation roller at the top of the slot in the frame, with the plungers facing downward.
- b. Start the threads of the pneumatic cylinder's piston rod clockwise into the top of the rocker assembly one full turn before starting the threads of the cylinder into the frame.
- c. Holding the rocker assembly, turn the pneumatic cylinder clockwise until it bottoms out on the top surface of the frame.
- d. Tighten the cylinder clockwise with the strap wrench.
- e. Tighten the jam nut clockwise onto the top of the rocker assembly using an adjustable wrench.
- f. Push the upper hose into the fitting on top of the pneumatic cylinder.
- g. Attach the guard to the front of the frame just below the pneumatic cylinder and tighten the four screws into the frame using a flat screwdriver.
- h. Attach the funnel block to the yoke using the screw provided and a 3mm hex wrench.
- i. Thread the tall standoffs into the inner tapped holes on the top of the base of the frame. Leave the standoffs slightly loose.
- j. Insert the pins of the lower nest into the lower set of holes in the front of the frame and position the nest over the standoffs.
- k. Insert the two screws provided through the nest and into the standoffs. Start the screw threads into the standoffs, tighten the standoffs with an adjustable wrench, then tighten the screws using a 4mm hex wrench.

Re-attach the inlet hose to the inlet fitting on the pressure regulator.

Review the Atlas 2K Operating Manual before proceeding.

WARNING! Adjust the pressure to 90 psi (6.2 bar) to start and never more than 105 psi (7.2 bar) during operation.

Convert from 50mL to 200mL (7015507)

WARNING! Disconnect the inlet hose from the pressure regulator.

Remove the necessary 50ml parts:

- Loosen and remove the screw holding the funnel block to the yoke using a 3mm hex wrench and remove the funnel block.
- Loosen the four screws holding the sheet metal guard using a flat screwdriver and remove the guard. The screws are designed to remain with the guard.
- Remove the lower nest and standoffs using a 4mm hex wrench and an adjustable wrench.
- Remove the hose from the fitting on top of the pneumatic cylinder.
- Loosen the jam nut at the top of the rocker assembly by turning counter-clockwise with an adjustable wrench.
- Loosen the cylinder from the frame by turning counter-clockwise using the strap wrench.
- Holding the rocker assembly, turn the pneumatic cylinder counter-clockwise until it separates from the frame and the rocker assembly separates from the piston rod. Set the cylinder and rocker assembly aside.

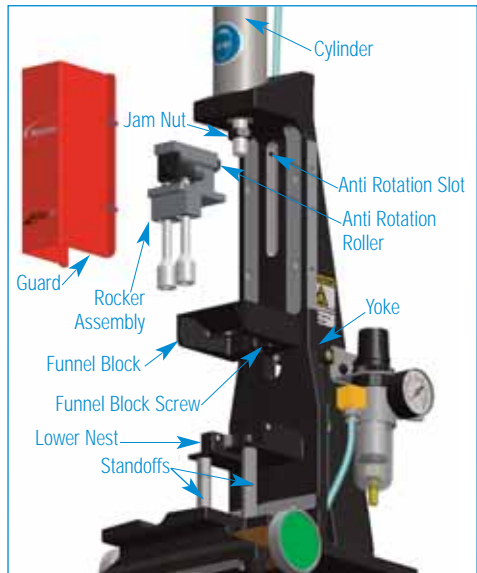

Install the necessary 200ml parts:

- Tip the Atlas 2K onto its left side (the side with the velocity control) and install the support bar and cap assembly using the screws provided and a 3mm hex wrench. (**NOTE:** The support cap should face up towards the nest when using open end cartridges, and down when using closed end cartridges.) Return the unit to the upright position.
- Position the rocker assembly with the rear anti-rotation roller at the top of the slot in the frame, with the plungers facing downward.
- Start the threads of the cylinder's piston rod clockwise into the top of the rocker assembly one full turn before starting the threads of the cylinder into the frame.
- Holding the rocker assembly, turn the pneumatic cylinder clockwise until it bottoms out on the top surface of the frame.

Convert from 50mL to 200mL (7015507)

- e. Tighten the cylinder clockwise with the strap wrench.
- f. Tighten the jam nut clockwise onto the top of the rocker assembly using an adjustable wrench.
- g. Push the upper hose into the fitting on top of the pneumatic cylinder.
- h. Attach the guard to the frame just below the pneumatic cylinder and tighten the four screws provided into the sides of the frame using a 2.5 mm hex wrench.
- i. Attach the funnel block to the yoke using the screw provided and a 3mm hex wrench.
- j. Screw the short standoffs into the outer tapped holes on the top of the base of the frame. Leave the standoffs slightly loose.
- k. Insert the pins of the lower nest into the lower set of holes in the front of the frame and position the nest over the standoffs.
- l. Insert the two screws provided through the nest and into the standoffs. Start the screw threads into the standoffs, tighten the standoffs with an adjustable wrench, then tighten the screws using a 4mm hex wrench.

Re-attach the inlet hose to the inlet fitting on the pressure regulator.

Review the Atlas 2K Operating Manual before proceeding.

WARNING! Adjust the pressure to 110 psi (7.6 bar) to start

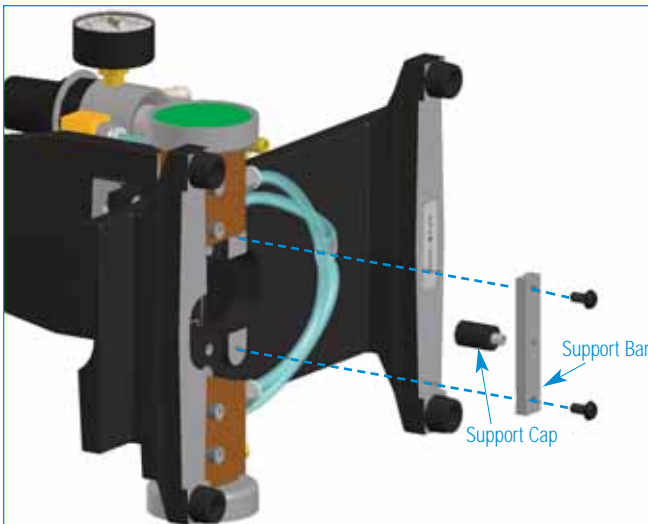

For Nordson EFD sales and service in over
30 countries, contact EFD or go to
www.nordsonefd.com

East Providence, RI USA
USA & Canada: 800-556-3484;
+1-401-431-7000
info@nordsonefd.com

Dunstable, Bedfordshire, UK
0800 585733;
+44 (0) 1582 666334
Ireland 00800 8272 9444
europe@nordsonefd.com

China: +86 (21) 3866 9006
china@nordsonefd.com

Singapore: +65 6796 9522
sin-mal@nordsonefd.com

The Wave Design is a trademark of Nordson Corporation.
©2010 Nordson Corporation
2KPISTON-CONVERT-01 7015504 v041610

Nordson EFD LLC

40 Catamore Boulevard
East Providence, RI 02914 USA

info@nordsonefd.com
www.nordsonefd.com

