

CE-20

Gun for Booster Paste

Combines two production proven valve technologies for the efficient application of materials that require different flow rates.

The Nordson CE-20 Gun for booster paste is designed for the application of multiple-part materials that require vastly different flow rates. Ideally suited for booster paste applications, the gun combines two production-proven Nordson dispensing valves into one precise, reliable tool. The gun incorporates a CE-20 valve to control the high flow of the single-component urethane and an AutoFlo™ module for the finer control of the lower flow booster paste.

During operation, the single part urethane flows down the outside of the gun manifold while the booster paste is introduced through the center of the material flow. Booster material is introduced immediately before the mix tube and is controlled with a zero-cavity needle, preventing premature curing and allowing for quick cleaning by replacing the mix tube.

The CE-20 Gun for booster paste can be used in a variety of applications, including (WHAT DO YOU USE THIS ON?). Different mix tubes are available to meet specific application requirements.

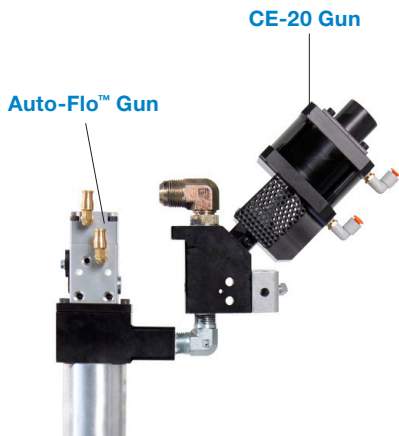

Versatile gun allows the selection of different mix tubes based on application requirements.



Features and Benefits

- Controls high-flow urethane and lower flow booster paste in one efficient process.
- Zero cavity needle controls booster paste flow to prevent premature curing.
- Replaceable mix tube allows for fast, easy cleaning.

Technical Specifications

Dimensions (without mixer tube)	17" h x 12" w x 4" d (36 cm x 30 cm x 10 cm)
Weight (without cylindrical aluminum spacer)	12.2 lbs (5.5 kg)
Air	60-120 psi (4 to 8 bar)
Temperature range	up to 180F (82 C)
Pressure	up to 5000 psi (335 bar)

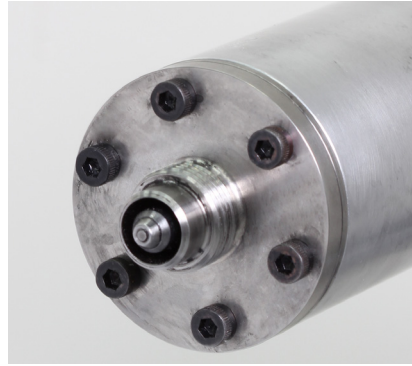

Zero cavity needle prevents pockets where material can cure.

For more information, speak with your Nordson representative or contact your Nordson regional office.

United States

Amherst, Ohio
+1.440.985.4000 **Phone**
+1.440.985.1683 **Fax**

Web:
www.nordson.com

Email:
automotive@nordson.com

Canada

Markham, Ontario
+1.905.475.6730 **Phone**
+1.905.475.8821 **Fax**

Web:
www.nordson.ca

Mexico

Edo. de Mexico, Mexico
+52.55.5301.1032 **Phone**
+52.55.5300.3004 **Fax**

E-mail:
ventas@nordson.com.mx

China

Shanghai, China
+86.21.3866.9166 **Phone**
+86.21.3866.9199 **Fax**

E-mail:
shanghai@nordson.com

Europe

Erkrath, Germany
+49.211.9205.0 **Phone**
+49.211.254658 **Fax**

E-mail:
automotive.eu@nordson.com

Japan

Tokyo, Japan
+81.3.5762.2700 **Phone**
+81.3.5762.2701 **Fax**

E-mail:
ppa.dm@nordson.co.jp

Web:
www.nordson.co.jp

© 2013 Nordson Corporation
All Rights Reserved

CML-13-5715
Issued 2/13