

# **APPLICATION VARIABLES FOR POWDER COATING SYSTEMS**

---

**Ken Kreeger  
Powder Systems Group  
Nordson Corporation**

**Published by  
Nordson Corporation**

**Introduction**

Despite the effect of several years of worldwide economic slowdown, the powder coating industry continues to grow in North America with an average annual rate (in pounds produced) of 12 to 15 percent. This rapid growth of powder coating has put a strong demand on equipment suppliers to develop more efficient ways of applying powder coating. The purpose of this paper is to provide an overview of powder application technology and variables that affect first-pass transfer efficiency.

**North American Thermoset Decorative Powder Coatings Production**

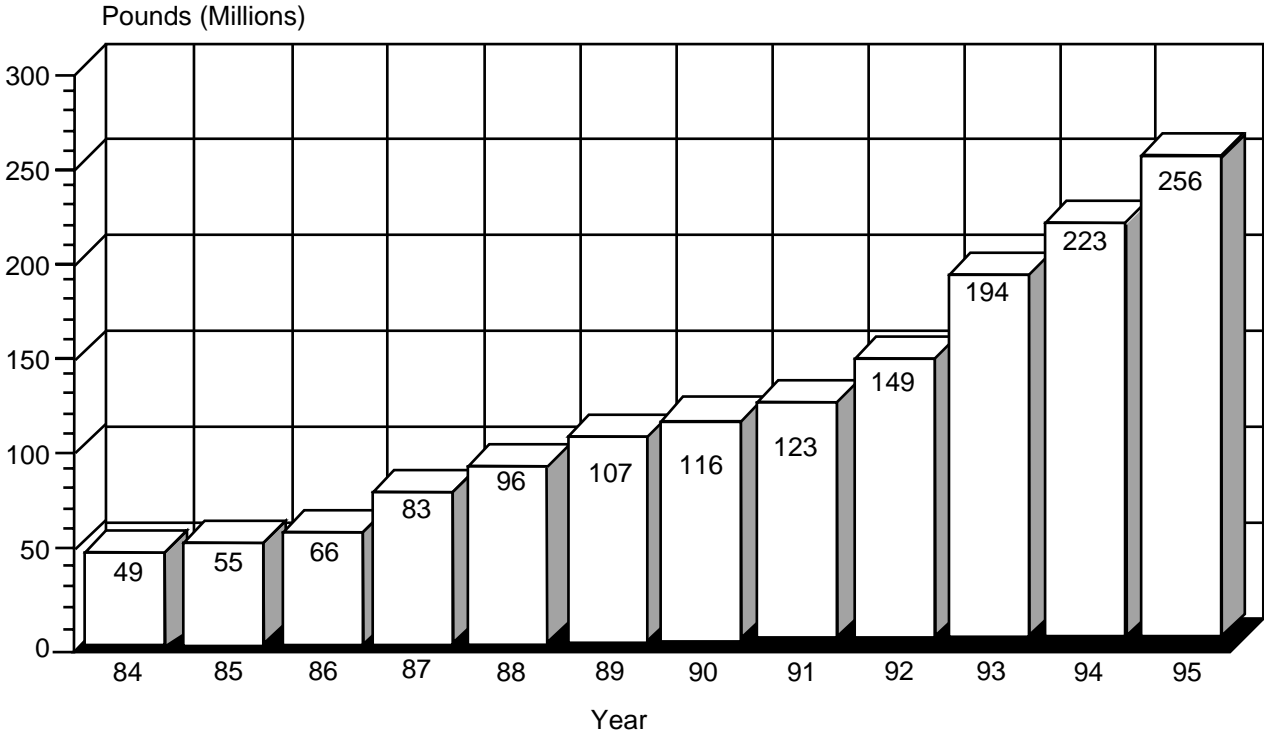

## Powder Coating Principle of Operation

The electrostatic application of powder coating to a part begins with fluidization. Fluidization is a process where powder being sprayed mixes with compressed air, enabling it to be pumped from a container and supplied to the spray guns. The powder flow is regulated by controlling the air supplied to the pump. The powder supplied to the spray gun is charged using either a corona or tribo-charging gun. Charged powder moves to the grounded workpiece with the help of air supplied to the guns and the airflow in the booth.

When the powder particles come close to the part, an electrostatic attraction between the charged powder particles and the grounded part adheres powder to the part. The coated part then passes through an oven and is cured. The oversprayed powder is contained within an enclosure and drawn into the primary filter cartridges by a centrifugal fan. Circulating air, now free of powder, is discharged through high-efficiency final filters into the plant as clean air. The primary filter cartridges are periodically reverse-pulsed to remove oversprayed powder. The powder is then sieved and supplied back to the guns to provide extremely efficient material for use again. A simple diagram showing how this process works is shown in Figure 1.

Figure 1 Flow Schematic

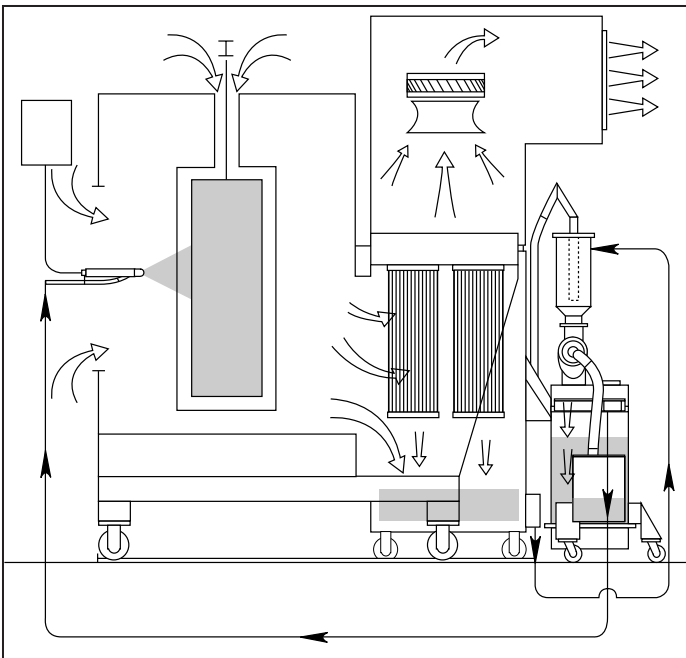

## Application Transfer Efficiency

What is first-pass transfer efficiency? It is defined as the amount of powder applied to the part compared to the total amount of powder sprayed by the application equipment. There are many variables to consider in achieving first-pass transfer efficiency. These variables and the applications that can affect first-pass transfer efficiency are discussed in the following pages of this paper (Figure 2).

Figure 2 Application Transfer Efficiency Variables

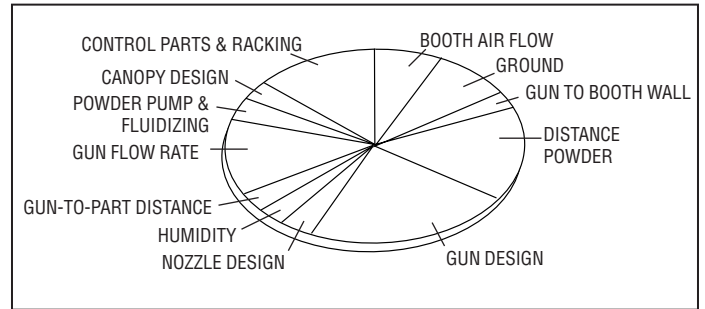

## Gun Design / Nozzle Design

Corona and tribo charging are two methods widely used in commercial electrostatic powder spray equipment. The most popular method used in North America today is the electrostatic spray process which is comprised of three main components (Figure 3).

Figure 3

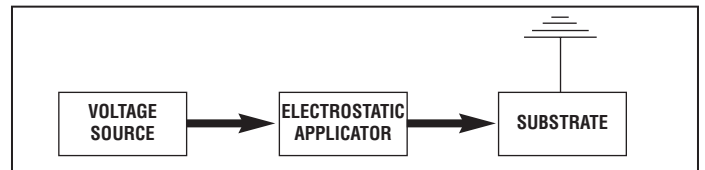

## Electrostatic Powder Spray Guns

Functions of the electrostatic powder spray gun are to:

- Shape and direct the flow of powder.
- Control the pattern size, shape and density of powder.
- Impart the electrostatic charge to the powder being sprayed.
- Control the deposition of powder onto the parts being sprayed.

## Charging System

The purpose of the charging system is to create a force within the sprayed powder particles enabling them to cling or attach themselves to bare, grounded metal parts as shown in Figure 4.

Figure 4 Corona Charging Powder Gun

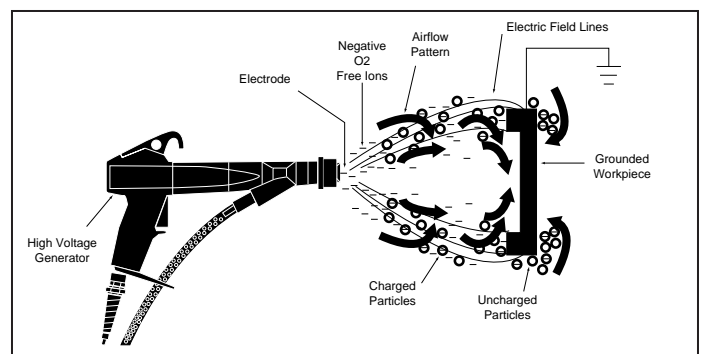

## Electrostatic Corona

High voltage or low voltage cables are the two basic ways that the voltage source is currently applied to the tip of a corona-charged powder spray gun. The type of cable depends on whether the high voltage generator is an external or internal power supply gun. Both come in negative or positive polarity. Generally, corona charging uses a negative polarity on the electrode as negative polarity produces more ions and is less prone to arcing than positive polarity. The charging electrode is held at a very high negative potential, requiring a power supply rated from 30,000 to 100,000 volts. Positive polarity guns are used when spraying nylon or touch up in an automatic tribo system. Figure 5 illustrates an external power supply gun and internal power supply gun for voltage generation.

Figure 5 Corona Charging Methods

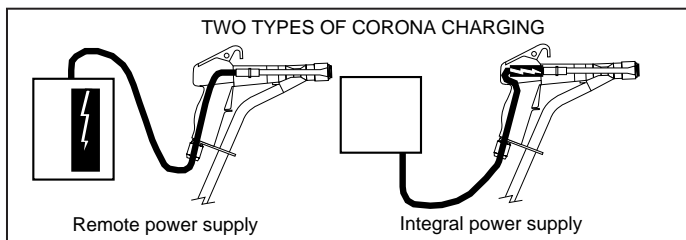

## Corona Design Criteria

- Charge in a region of high field strength.
- Charge where air velocities are low.
- Charge where the powder is well dispersed.
- Arrange the geometry of the charging electrode so the ions flow through the powder stream and the electrode is in the direct line of sight of the ground.

The above design features should be consolidated with the pattern of powder flow, equipment cost(s), ease of maintenance, and durability.

## Tribo Charging

The word tribo is derived from the Greek word tribune, meaning to rub or produce friction. In tribo charging, the

Figure 6 Tribo Charging Powder Gun

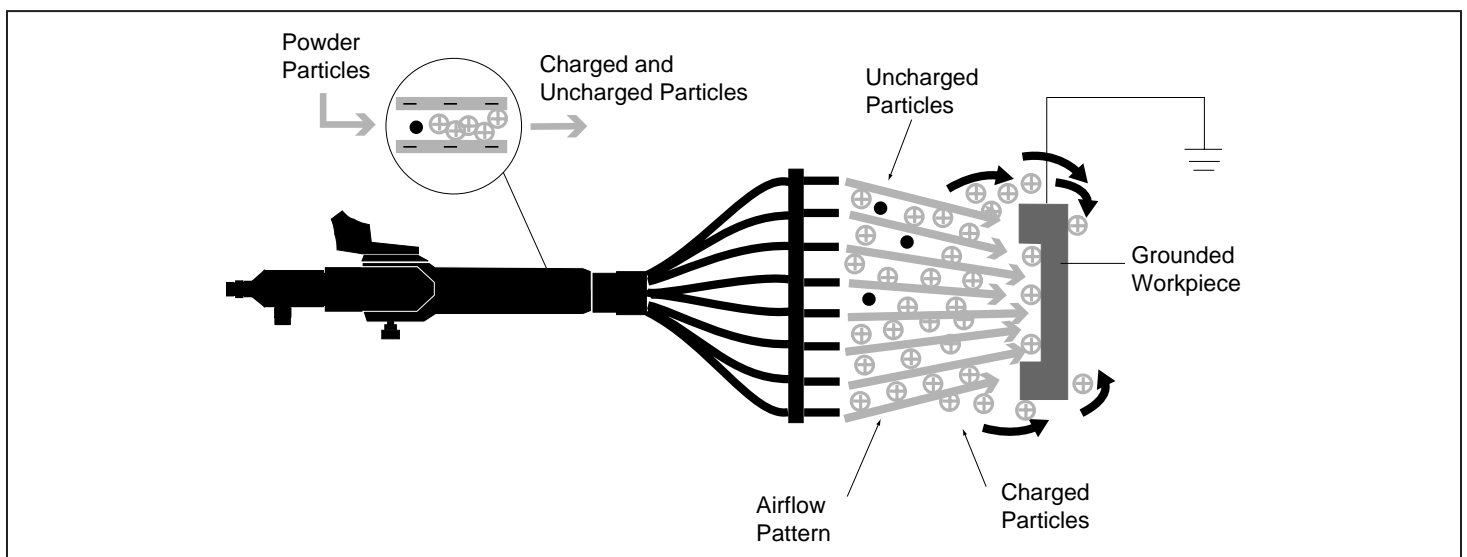

powder particles are charged by causing them to rub at a high velocity on a surface and thereby, transferring the charge (Figure 6). Without an external power supply and a charging field in front of the gun, tribo charging virtually eliminates the problem of "faraday cage effect." The powder particles take on a positive charge inside the gun due to the loss of electrons. The particles are now free to be directed to where they are needed. The powder flows into recessed and difficult-to-reach areas by nozzle direction and air flow. Because the particles are charged in the gun and there are no lines of force, it is less likely that the powder particles will build up on the leading edge of the part being coated. The advantage to this is the near elimination of "fatty edges" resulting in a uniform coating and even film build on the product.

One thing to note, tribo charging is much more dependent on correct powder formulation (chemically) and particle grind size than corona-charging equipment. It is imperative that all powders be tested in tribo equipment to ensure good results.

## Powder Spray Guns

The two major gun categories are manual and automatic.

Manual guns can be used in stand-alone units, applications not requiring automatic guns, or with automatic systems that are generally used for difficult-to-reach and/or complex parts.

Since the hand painter uses the spray gun for long periods of time, the flexibility, weight, efficiency and durability of the spray gun are important. When considering the added mass of the hose and cable, keep in mind that most painters will hold the hose and cable with the other hand so that only three or four feet of hose and cable weight are added to the gun. Also, depending on where the hose and cable are attached to the gun, the added weight may improve or degrade the overall balance. (Note: Work with your equipment supplier to help determine the right nozzle type for your application.)

Automatic guns may be fixed, on gun movers, or a combination of both. In many cases, systems may be totally automatic without handguns for touch up.

Here are six things to consider before you purchase your next powder gun:

- Is the gun easy to disassemble and reassemble?
- Is there a variety of nozzles?
- Ease of cleaning for color change?
- How many wear parts?
- Where is the manufacturing facility?
- Test the gun on your parts.

Each type of gun has its place in the market depending on the application. The justification for each has to do with its specific design and overall chargeability. The most important thing to remember is the powder gun is just one piece of the application pie.

### Nozzle Design

The gun and nozzle design is a major influence in achieving first-pass transfer efficiency. As previously discussed, charge where air velocities are low and where the powder is well dispersed. This is where the nozzle design comes into place. The two most widely used nozzles are the deflector-pattern nozzles and flat spray nozzles. Both are available in various pattern shapes. The flat spray nozzle is more directional and has a well-defined pattern. The deflector-pattern nozzle has a soft, well-dispersed pattern and has the appearance of a liquid bell. There are many other nozzle types, but these account for 90 percent of the usage in today's powder coating systems. There are gun extensions that will help you reach deep recessed parts safely and without too much effort (Figure 7).

Figure 7 Nozzle Selection

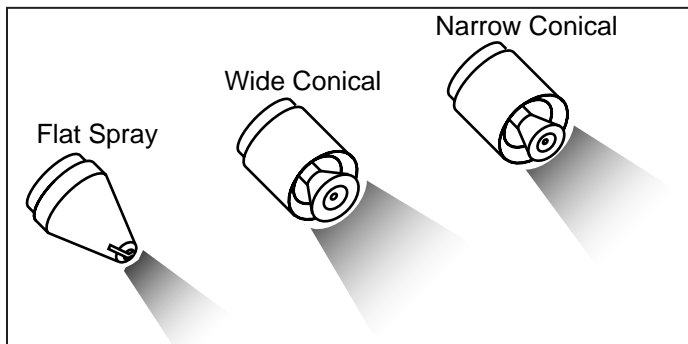

### Powder Pump and Fluidizing Gun Flow Rate

The purpose of the pump is to supply powder to the gun at a uniform and consistent rate. Powder pumps use a venturi principle to deliver powder from a supply hopper to the powder spray gun. The lowest flow rate possible is the ideal condition for first-pass transfer efficiency while still maintaining coverage through each gun. Consistent with the theory of high-charging efficiency is control of the powder output of the guns. The more powder passing by the gun electrode, the less chance each particle has in picking up the maximum charge. More powder flow is not better when dealing with transfer efficiency. It is better to add additional powder guns to keep outputs low than to reduce the number of guns and increase the output per gun.

A fluidizing hopper/feeder with level control is probably the most overlooked and underrated device of any powder system. Let's look at some of the critical design criteria of a fluidizing hopper:

- Level control.
- Fluidizing plenum.
- Venting.

A good level control will enable the fluidizing feeder to maintain a consistent powder height and a consistent feed rate.

The fluidizing plenum is designed to distribute the air uniformly across the fluidizing membrane which in turn provides uniform fluidization throughout the interior of the feed hopper. More fluidizing air flow is not better when dealing with transfer efficiency. Too much air or non-uniform distribution of that air will result in extremely violent fluidization in certain areas. As a result, efficiency of the powder pump will be reduced causing the powder pump to draw air and reduce the powder flow rate.

A powder feed hopper is like a pressure vessel in some ways. The feed hopper receives powder through three to four venturi transfer pumps. These pumps are basic and air-type pumps, and the air pressure from the pumps and the fluidizing bed has to be relieved from the hopper feeder. The best way to remove the excess air is through a direct vent design. This design relieves internal pressure back to the collector as shown in Figure 8.

Figure 8 Powder Feed Hopper

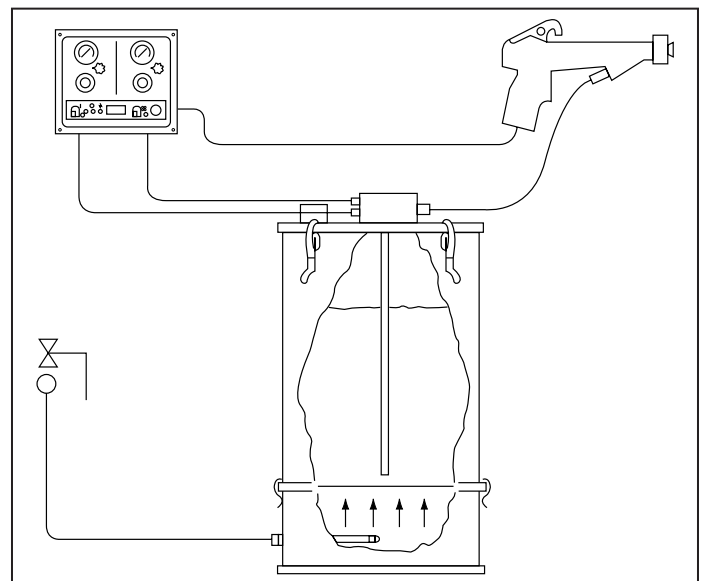

### Controls / Parts and Racking

Process control and monitoring devices can enhance the operating efficiency of your powder coating system. When you look at first-pass transfer efficiency, consider a system where the guns are triggered on at all times and the space between the parts is equal to the part size. The highest achievable first-pass transfer efficiency of your system will be no more than 50 percent because one-half of the powder is sprayed into the air. Using a stop watch,

record the amount of time the guns are spraying without parts in front of the gun. System history has shown us that the time will vary from 20 to 60 percent of the time the guns are spraying with known parts in front of the guns.

Your overall first-pass transfer efficiency could improve from 20 to 60 percent based on gun triggering. An added benefit of automated gun triggering is the ability to adjust the spray duration to either reduce heavy edges on parts or to increase wrap on parts (Figure 9).

Figure 9 Automatic Gun Triggers

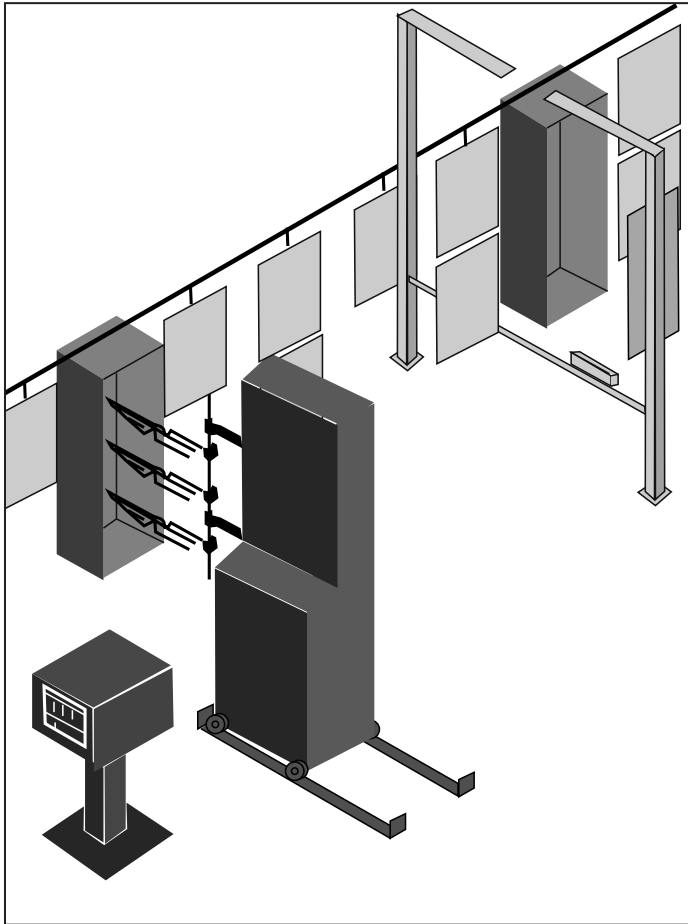

### Booth Air Flow

Uniformity in the booth air flow is one key piece of the application variables chart. Previously we discussed that “more powder flow is not better when dealing with transfer efficiency.” “More air flow” will also affect your first-pass transfer efficiency. As this section of the paper deals with application transfer efficiency variables, powder booths are designed with two requirements; 1) powder containment and 2) safety. We will focus on powder containment.

The first requirement in any powder system is powder containment. To contain oversprayed powder particles, the powder booth is designed to provide average face velocity of 100 lineal feet per minute (lfpm) air flow across all openings.

Following are some exceptions:

- Tall parts greater than 6'0".
- Heated parts greater than 120° F.
- Crossdrafts in excess of 60 FPM in area of the booth.
- Short hooks up to 18".

Again, we are looking for powder containment. Too much air flow will draw the powder away from the parts being coated. Many try to overcompensate with a higher powder flow rate and less first-pass transfer efficiency.

### Booth Canopy Design

The design of a powder coating booth begins with the canopy or enclosure that contains the oversprayed powder. The canopy is best described as a small room with four walls, a floor and a ceiling. The ceiling has a slot running lengthwise through which hangers from the conveyor protrude to support the part to be coated. Because powder is applied via an electrostatic charge and our goal is high first-pass transfer efficiency, we want the powder to be attracted to the part and not to the booth. To achieve this, the booth canopy or the area around the automatic powder guns should be constructed of a low, non-conductive material. This will allow the electrostatic field emitted by the guns to attract the powder to the part and not the booth wall.

#### • Gun-to-Booth Wall Distance

One canopy issue that will affect first-pass transfer efficiency and good housekeeping is the distance of the tip of the gun to the booth canopy behind the gun. The powder gun should be at least 12 inches inside the booth so the electrostatic field is attracted to the part and not to the booth canopy. If the base of the powder booth is not wide enough to place the gun inside the booth, you can add a booth wall extender at the gun opening for added space between the gun tip and the wall. As a result, more powder is attracted to the part, increasing operating efficiency. This also speeds up booth cleaning during color changes.

#### • Gun-to-Part Distance

The distance between the parts you are coating and the tip of the gun will affect your transfer efficiency. There are many variables with gun placement that depend on line speed and part specification. Generally, start at 8 to 12 inches away from the part.

### Humidity

Both humidity and temperature can affect the performance of a powder coating system. The powder system should be installed in an environmental room. The value of an environmental room is consistency as any change in temperature and humidity may affect fluidization, filter efficiency, filter life, and charging capabilities of the powder.

Temperature of the environmental room should remain at 68° F to 80° F.

Relative humidity should remain at 47 to 55 percent.

## **Ground**

Part grounding is extremely important. An ungrounded substrate will attract the charged powder to a certain point. After which, it begins to repel the charged material. It will also affect your first-pass transfer efficiency. An ungrounded part has the potential to ignite the powder and create a fire.

Ground is measured as one megohm resistance.

## **Powder**

There are physical and chemical properties that can affect first-pass transfer efficiency. Not all powders are the same, so I would recommend you work with your powder supplier.

## **Summary**

In the past decade, powder coatings have come a long way. The full potential in North America remains to be realized. The value of first-pass transfer efficiency is important, but let's not fool ourselves. First-pass transfer efficiency is more than a powder gun. It's a totally integrated system. In some cases, a piecemeal system may look like a powder coating system but the overall performance, operating cost, quality and system efficiency fall short of a totally integrated powder coating system.

Future developments in the powder coating equipment industry will focus on first-pass transfer efficiency. It could be economically feasible to spray-to-waste by increasing the transfer efficiency of the application equipment. As a result, we would achieve a faster color change equal to that of a liquid paint system.



When you expect more.™

Nordson Corporation • 1150 Nordson Drive • Amherst, Ohio 44001 • (800) 626-8303